

NETWORK COMPATIBLE RELAYS

RIBMNW24B-BCAI

2.75" Track Mount BACnet® MS/TP Network Relay Device with Binary Output Set Point Function; One Binary Output (20 Amp Relay SPDT + Override); Two Binary Inputs (Dry Contact, Class 2); One Analog Input (T2/T3 Thermistor / 0-5 Vdc / 0-10 Vdc); 24 Vac/dc Power Input; **Optional End of Line Resistor (EOL) Included.**

RIBTW24B-BCAI

Enclosed BACnet® MS/TP Network Relay Device with Binary Output Set Point Function; One Binary Output (20 Amp Relay SPDT + Override); Two Binary Inputs (Dry Contact, Class 2); One Analog Input (T2/T3 Thermistor / 0-5 Vdc / 0-10 Vdc); 24 Vac/dc Power Input; **Optional End of Line Resistor (EOL) Included.**

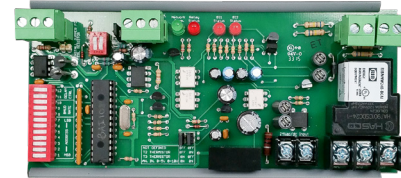

Code Version 1.5

RELAYS

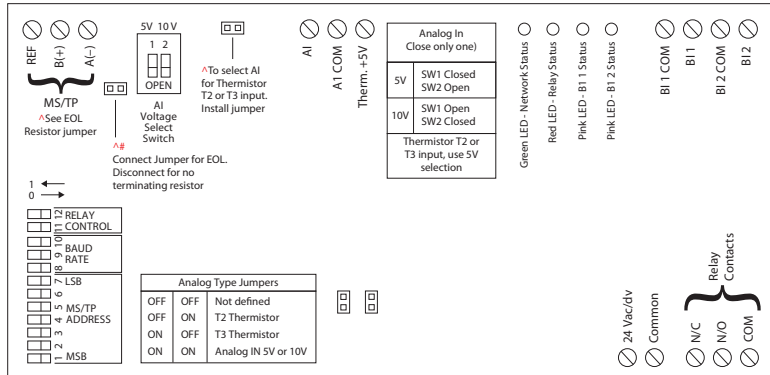

SPECIFICATIONS

- # Relays & Contact Type:** One (1) SPDT Continuous Duty Coil
- Expected Relay Life:** 10 million cycles minimum mechanical
- Operating Temperature:** -30 to 140° F
- Humidity Range:** 5 to 95% (noncondensing)
- Operate Time:** 18ms
- Network Communication:** Green LED
- Relay Status:** Red LED On = Activated
- BI1 Status:** Pink LED On = Activated
- BI2 Status:** Pink LED On = Activated
- Dimensions:** 6.25" x 2.75" x 1.75" (RIBMNW24B-BCAI)
4.28" x 7.00" x 2.00" with .75" NPT Nipple (RIBTW24B-BCAI)
- Track Mount:** MT212-6 Mounting Track Provided
- Approvals:** CE, UL Listed, UL916, C-UL, RoHS
- Housing Rating:** UL Listed, NEMA 1, C-UL, CE Approved, UL Accepted for Use in Plenum, Also available NEMA 4 / 4X
- Gold Flash:** No
- Relay Override Switch:** DIP Switch Control (See Bulletin B1243)
- Network Media:** Twisted Pair 22-24AWG, shielded recommended
- Terminations:** Functional Devices product installed at both ends of the MS/TP network – Use 120 Ω end of line resistors. All other cases – Follow instructions from the device installed at the end of the MS/TP network.
- Polarity:** Network is polarity sensitive
- Baud Rate:** 9600, 19200, 38400, 57600, 76800, 115200 (DIP Switch Selectable – See Bulletin B1243)

- Contact Ratings:**
 - 20 Amp Resistive @ 277 Vac
 - 20 Amp Ballast @ 277 Vac
 - 16 Amp Electronic Ballast @ 277 Vac (N/O)
 - 10 Amp Tungsten @ 120 Vac (N/O)
 - 1110 VA Pilot Duty @ 277 Vac
 - 770 VA Pilot Duty @ 120 Vac
 - 2 HP @ 277 Vac
 - 1 HP @ 120 Vac

- Power Input Ratings:**
 - 81 mA @ 24 Vdc
 - 111 mA @ 24 Vac

• PIC Statement available on website.
http://www.functionaldevices.com/pdf/pics/BACnet-BCAI_PICS.pdf
Or scan QR code with your smart phone.



- Notes:**
 - Order NEMA 4 housing by adding "-N4" to end of model number. (RIBTW24B-BCAI-N4)
 - Order with grey lid by adding "-GY" to end of model number. (RIBTW24B-BCAI-GY)
 - Order NEMA 4 housing with grey lid by adding "-N4-GY" to end of model number. (RIBTW24B-BCAI-N4-GY)
 - For all versions, raw analog default settings are 0 and 1023 (real), respectively. Units default to 95 (no units). For Set Point Function settings, See Bulletin B1243
 - When connecting 24 Vac to both the RIB(s) and a half-wave device, damage to device can occur.**
 - Option 1: Use separate transformers for each device.**
 - Option 2: Add diode between devices, (See Bulletin B1243 for diagram)**

- BACnet® Details:**
 - MS/TP Address & Baud Rate must be set prior to power up via DIP switches.
 - Device ID will default to 277XXX where XXX is the MS/TP Address.

| | |
|---|---|
| MS/TP Address - 004 Device ID - 277004 | MS/TP Address - 121 Device ID - 277121 |
|---|---|

- Device ID can be changed via network command. Once changed, it will no longer default to 277XXX. (MS/TP Address & Device ID must be unique.)
- This model utilizes: BO 1 (Relay output), BI 1 (Dry contact binary input), BI 2 (Dry contact binary input), AI 1 (Analog input), AV1 (Set Point), AV2 (Differential), BV1 (Function Enable), BV2 (Function Mode), BV3 (Function Status)
- Device Instance changed via Object Identifier Property of Device Object

- Thermistor Specifications:**
 - Thermistor Type 2 (T2) Precon 10 K @ 77°F (25°C) PN ST-R24, Model 24, (or equivalent.)
 - Thermistor Type 3 (T3) Precon 10 K @ 77°F (25°C) Model 3, (or equivalent.) Thermistor not included.

- For both T2 and T3, MIN_PRES_VAL must be set to -36 (real value) and MAX_PRES_VAL must be set to 66.3 (real value) for Celsius. For Fahrenheit, MIN_PRES_VAL must be set to -32.8 (real value) and MAX_PRES_VAL must be set to 151.34 (real value).
- 35 to 10°C range in 1° steps / -31 to 50°F range in 1.8° steps
10 to 32°C range in 0.1° steps / 50 to 90°F range in 0.18° steps
32 to 100°C range in 1° steps / 90 to 212°F range in 1.8° steps

Set Point Function

for App. Version 1.5 or higher

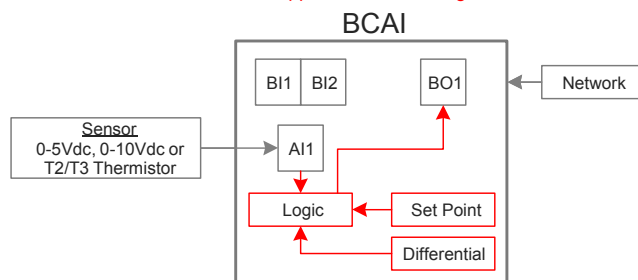

Set Point Function must be enabled via the Network for logic to execute. Once configured, the function will continue to operate even if communication is lost (see Bulletin B1243 for setup).